

# Required Upper-Division Core Courses for Civil Engineering

## 2020-2021 Catalog Year

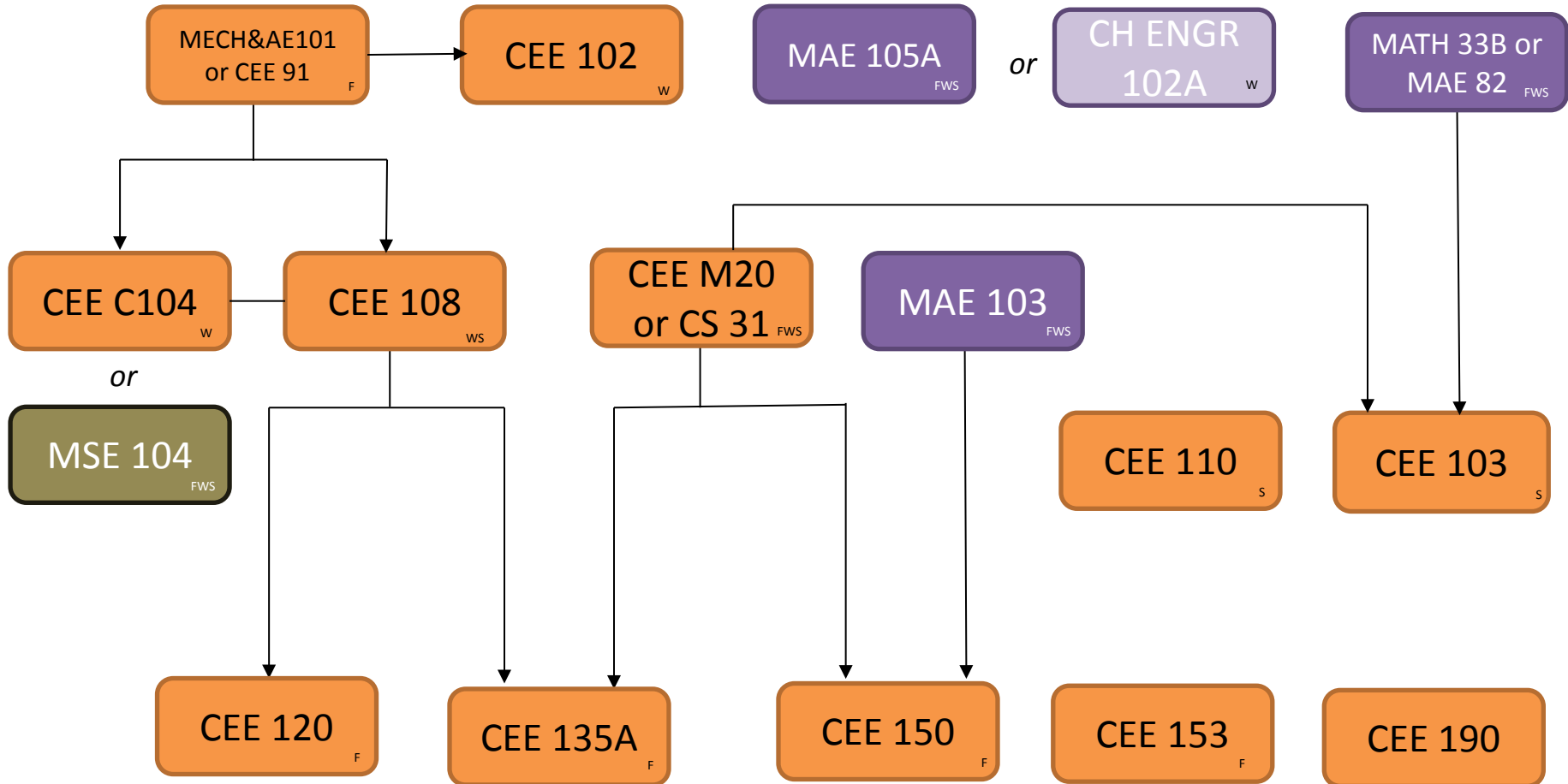

This chart is current and valid for the 2020 – 2021 Academic Year and may be subject to change.

**Please note:** Upper-division courses have lower-division requisites that you must complete. Requisites and term offerings can change.

**Make sure you are using the most current information when planning your courses.**

Please connect with your OASA Counselor if you have any questions regarding your degree plan.

F=Fall Quarter W=Winter Quarter S=Spring Quarter